

FLANGED NO THREAD CD - #10 PUSH NUTS

Aluminum Alloy 5000 Series

L = 3/8" - 1 1/4"

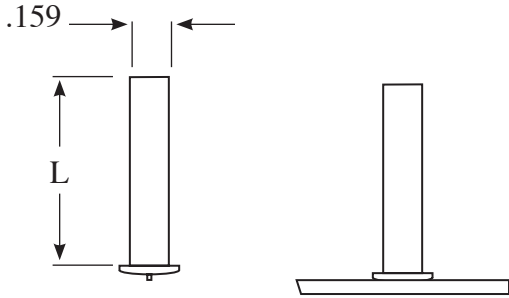

Reusable
Pushes On
Screws Off

#10 Push Nut

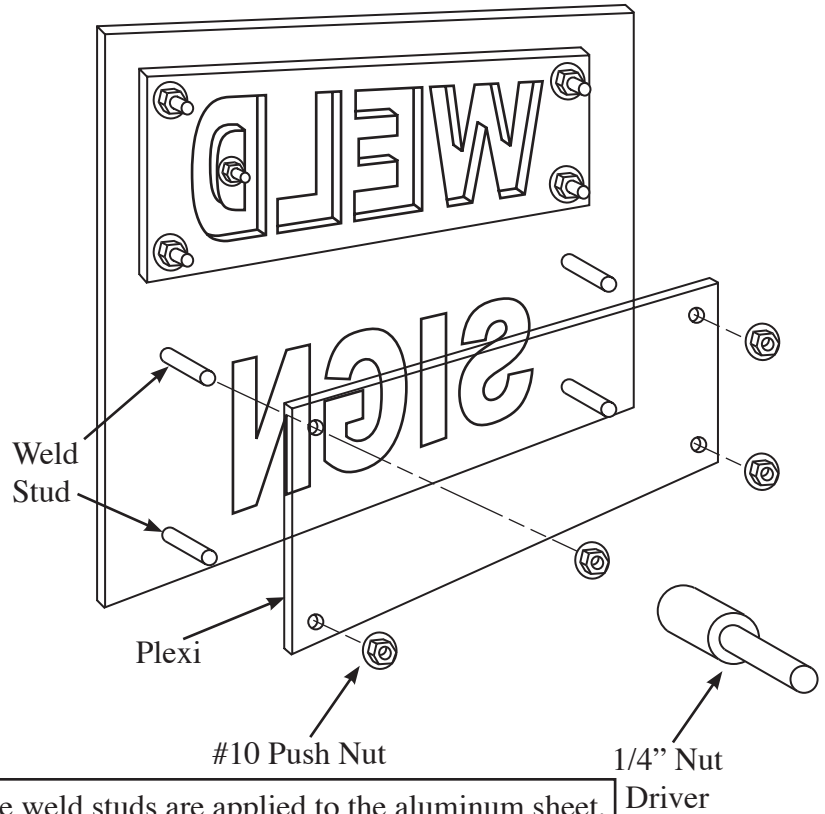

- (1) The weld studs are applied to the aluminum sheet.
- (2) The plexi glass is placed over the studs.
- (3) Use 1/4" nut driver to install the push nuts. The push nuts will hold the plexi glass in place.

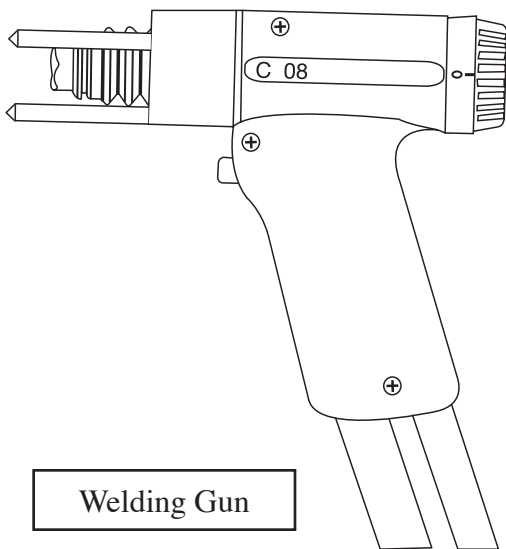

Welding Gun

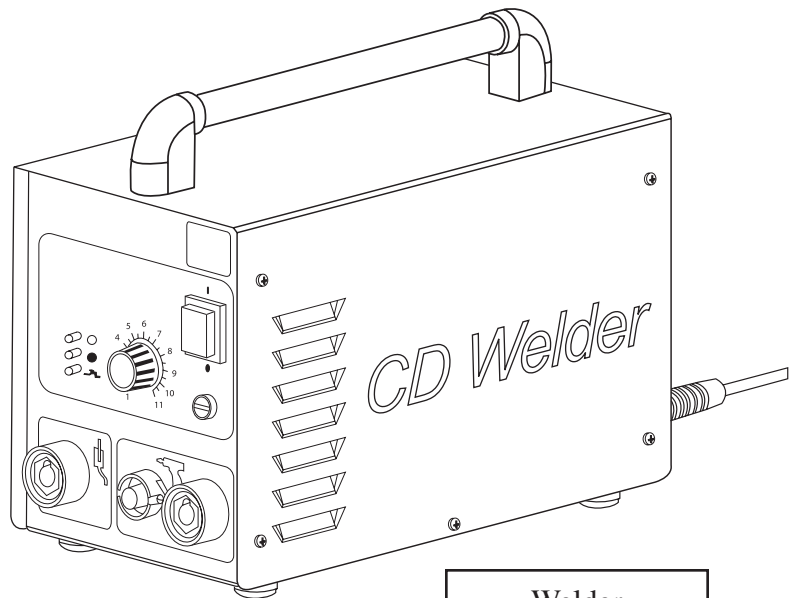

Welder