

SECTION A-A

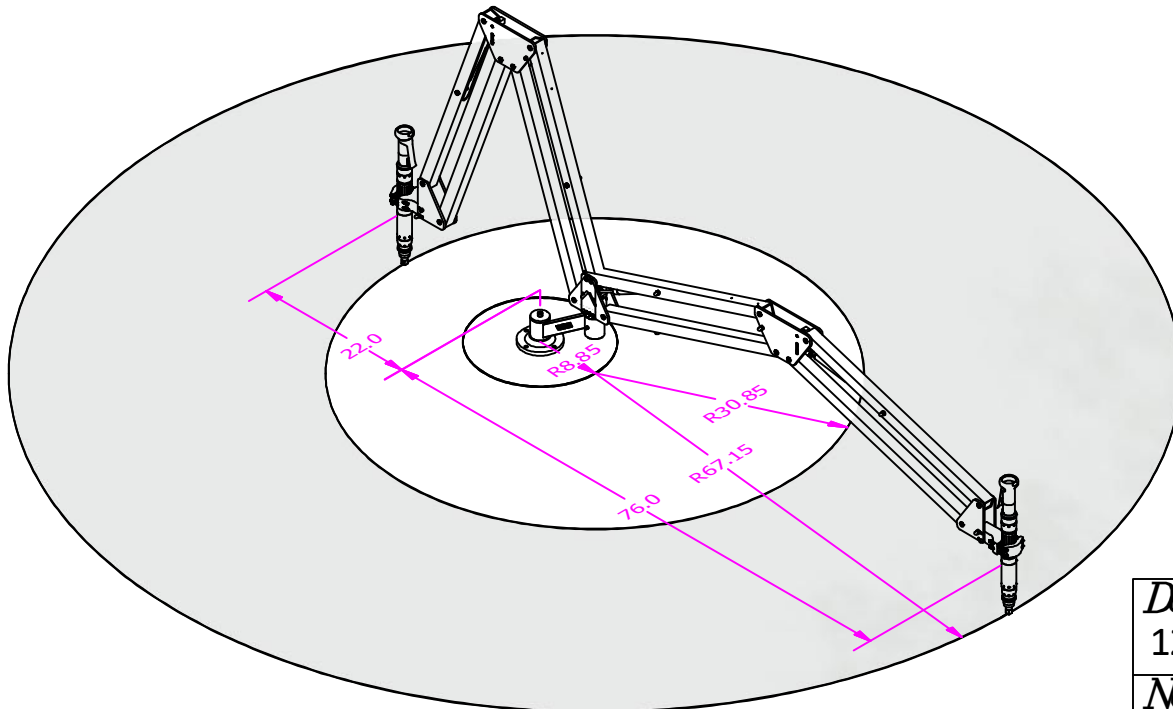

NOTES:

- TOOL IN IMAGE ABOVE SHOWN FOR REFERENCE ONLY
- STANDARD V-BLOCK ACCEPTS TOOL DIAMETERS Ø1" TO Ø2.25"
- MAX COUNTERBALANCE CAPACITY IS 25 LBS
- TOOL WEIGHT MUST BE PROVIDED AT ORDER
- MAX TORQUE MUST BE PROVIDED AT ORDER

<i>Date:</i> 12/18/2017	<i>Tolerance:</i> .00.....±.010 DECIMAL: .000.....±.005 .0000.....±.0005	<i>Drawn By:</i> crieman	<i>Option No.:</i> M-60
<i>Name:</i> M-60 (ARM ONLY) WORKING RANGE			
<i>Material Specs:</i>			<i>Sheet:</i> 1 OF 1
			<i>Part No.:</i> M-60 WORKING RANGE